

**ISUZU**

**DIESEL**

**ALTERNATIVE  
FUELS**

**4HV1**

**Dependable Power**

**LP** - 82.5 HP (61.5 KW) @ 1800 RPM

**LP** - 56.3 HP (41.9 KW) @ 2200 RPM

**Natural Gas** - 78.4 HP (58.5 KW) @ 1800 RPM

**Natural Gas** - 79.8 HP (59.5 KW) @ 2200 RPM

# ALTERNATIVE FUEL

(a natural progression)

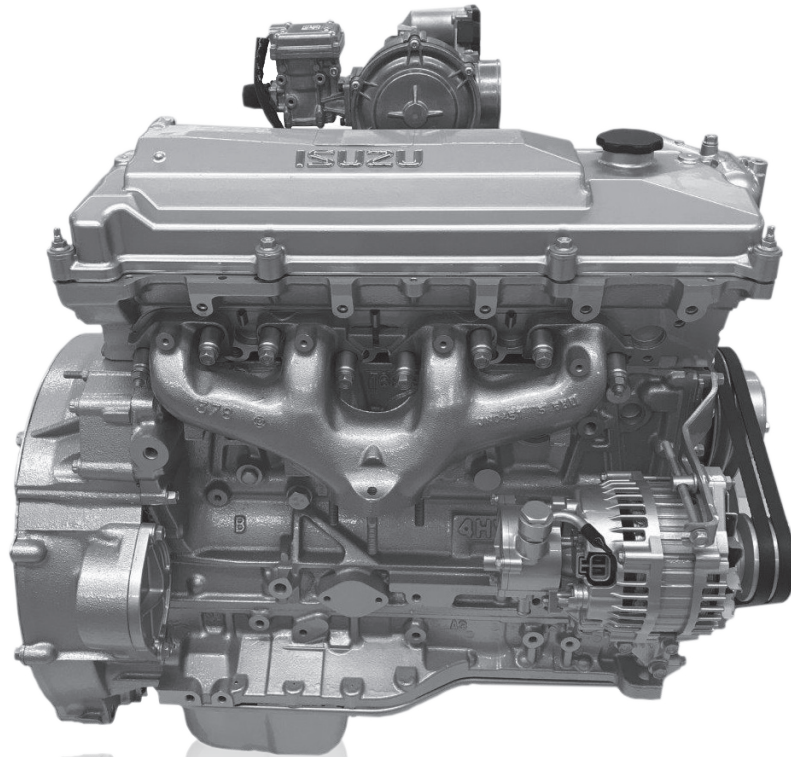

Switchable dual fuel capable use in off-highway and industrial applications make this **alternative fuel engine** a natural progression.

**Certifications**

U.S. EPA Tier **2** stationary  
Phase 3 Class **III** emergency stationary

[isuzuengines.com](http://isuzuengines.com)



**Applications**

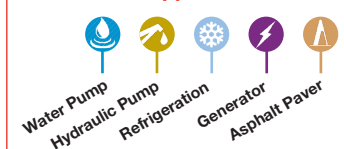

**ISUZU**  
**DIESEL**

## Performance

### Engine Performance Curves

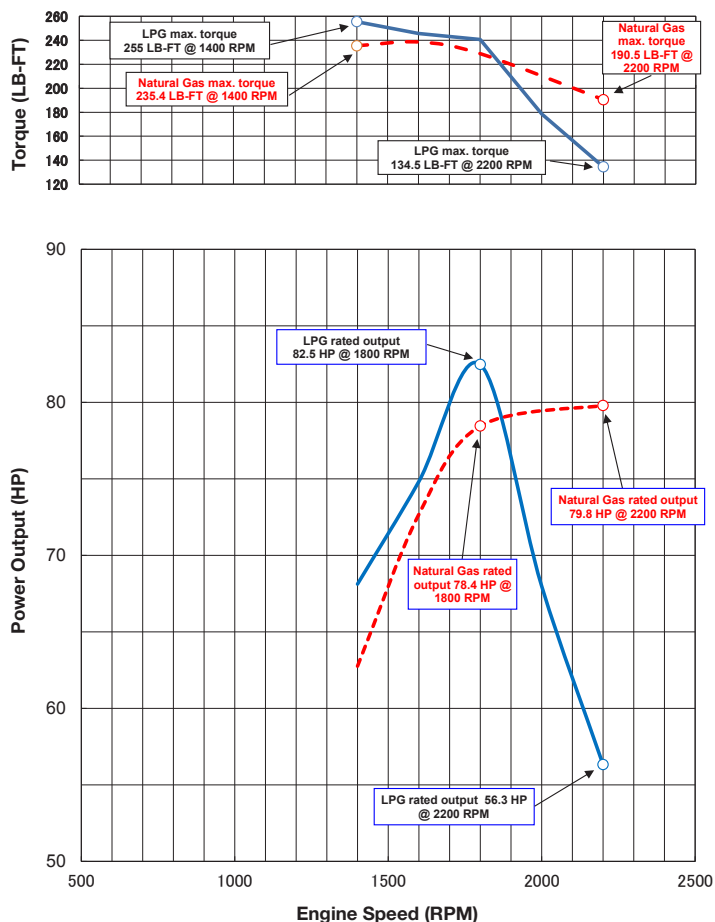

### Standard

- Maintenance free 3-way catalyst\*
- Flywheel housings: SAE #3
- Mixer
- Electronic Pressure Regulator
- Wire Harness
- Knock Detection
- Vaporizer (LP only)
- ECM
- Spark Ignition
- Dry/replaceable cylinder liners
- 2-year / 2,000-hour warranty
- 500-hour oil drain & service interval

### Available Options

- Bottom drain oil pan
- Cooling package
- Air cleaner
- Engine mounting
- Skid base
- Remote Oil Filter
- Isolated / non-isolated power unit
- Muffler for emergency standby

\*For LSI T2 applications

### Engine Performance Curves

- 4HV1 LP
- 4HV1 NG

For additional information, please contact your local distributor or visit [isuzuengines.com](http://isuzuengines.com)

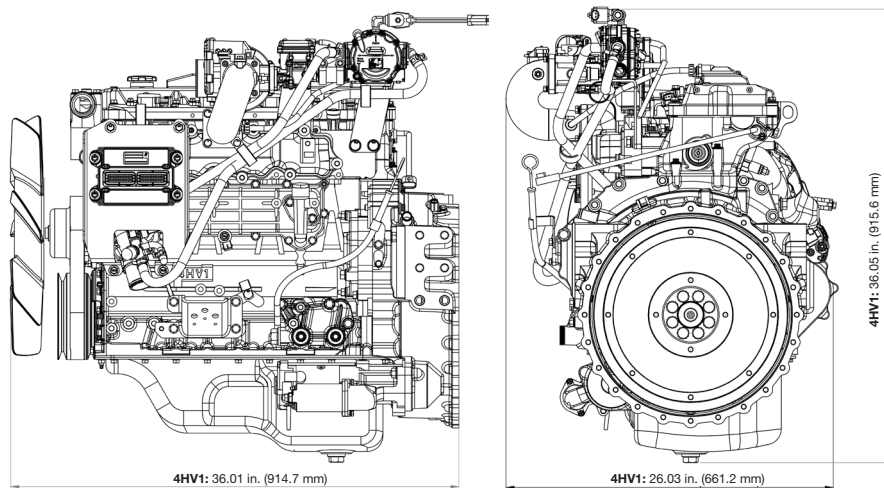

### Isuzu Motors America, LLC

46401 Commerce Center Drive  
Plymouth, Michigan 48170  
Phone: 734.582.9470  
Fax: 734.455.7581