

ISUZU 4LE2

52.4 Horsepower
Industrial Diesel

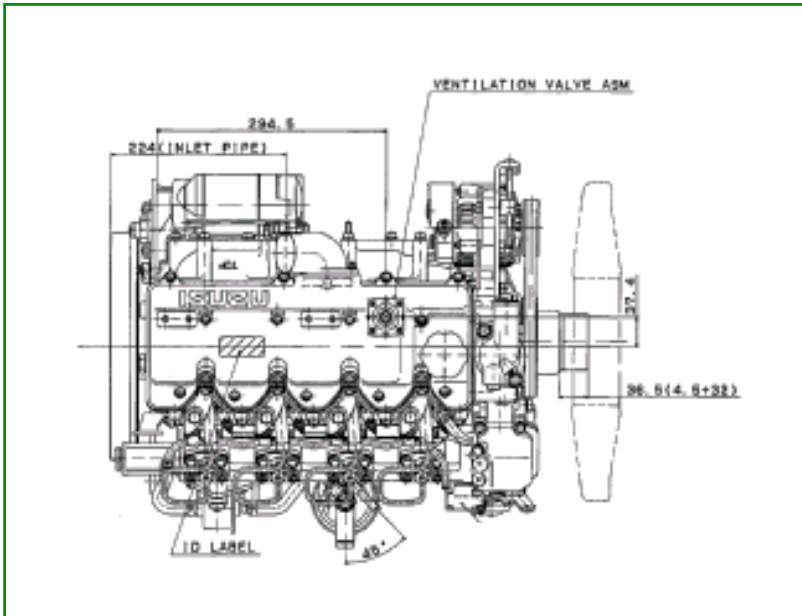

MAIN SPECIFICATIONS

Type	4-Cylinder, 4 Cycle, Water Cooled, OHV, In-Line, Direct Injection
Bore & Stroke	3.35 x 3.78 in. (85mm x 96mm)
Engine Displacement	2.2 L
Compression Ratio	18.8:1
Dry Weight	299 lbs. (135.5 kg)
Dimensions (L x W x H)	25.7 x 19.2 x 23.7 in. 654 x 488 x 602 mm
Coolant Capacity	3.0 qt. (2.8 L)
Lube Oil Capacity	8.6 qt. (8.1 L) (less filter)

MAIN FEATURES

Alternator	12V – 35A
Voltage Regulator	Internal
Starter	12V – 2.0kW
Exhaust Outlet	Sideward
Air Inlet	Rearward Upward
Flywheel Housing	Flat Rear Plate
Flywheel	Thin SAE Type for 7.5" Over Center Clutch
Oil Pan	30° Inclination All Directions
Fan	15.7 in. (400mm) Suction

INDUSTRIAL RATING*

Rated Output	52.4 BHP @ 3000 RPM
Max Torque	105 lb. ft. @ 2250 RPM

*SAE J1995 Gross BHP

Specifications subject to change without notice.

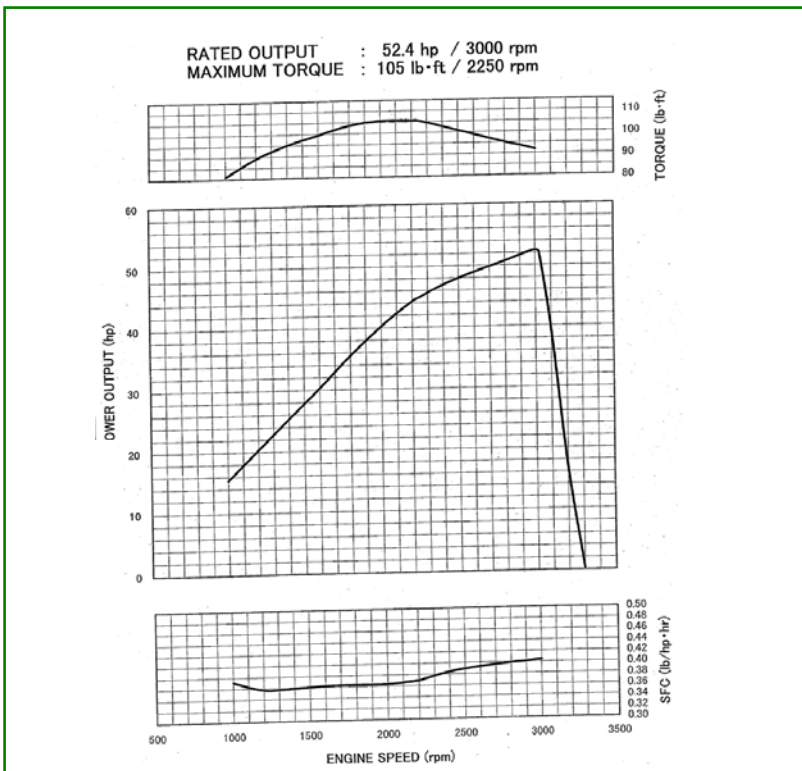

ISUZU MOTORS AMERICA, INC.
PowerTrain Division

ISUZU
DIESEL

46401 Commerce Center Drive • Plymouth, MI 48170
PHONE: 734.582.9470 • FAX: 734.455.7581
www.isuzuengines.com